

**GUIDELINES**

Step 1 - Please fill out the table below to provide the Sign Code and Permit requirements for the project.

- Send back the filled out form together with the photo of building or tenant's space.

Step 2 - Complete the requirements for the Sign Permit application to start the process.

Step 3A - If the Sign Permit application needs to be mailed to the City, the Client will need to set up a UPS account to mail the documents. We will handle creating a label from the UPS account that the Client's created. (See pages HOW TO CREATE UPS ACCOUNT)

- After creating a UPS account, send all the requirements to us so we can compile everything and we will send it back to you with a label for mailing.

Step 3B - If the Sign Permit application will be sent via email or online application only, Client needs to send all the requirements to Signage Permit Consultants to start the application process.

Step 4 - You will receive an update every 4 days or weekly for the status of Sign Permit application.

Project Name : Tropical Smoothie Cafe STORE# IL 038	Date :
Project Address : 808 N Milwaukee Ave Buffalo Grove, IL 60089	

BUSINESS INFORMATION / CLIENT		
Company legal name including DBA:		
Business Address :	City :	State, Zip Code : IL 60089
Phone number :	Email :	Fax : N/A
Owner's name :		
Home Address :	City :	State, Zip Code : MI 48098
Phone number :	Email :	Fax : N/A

LANDLORD INFORMATION		
Property Owner's Full Name: Richard Silverman		Position : Owner
Company Name : MJK Real Estate Holding Company		
Address : 1622 Willow Rd Ste 201	City : Northfield	State, Zip Code : IL 60093
Phone number : 847-530-9512	Email : rseusanfsc.com	Fax : N/A

BUILDING OR TENANT'S SPACE INFORMATION	
Space Length : 25.42 ft	Space total floor area : ---
Space Width : ---	Height of wall (1st floor only) : 22.82 ft ; height of concrete wall - 9.58 ft
Building Length : ---	Lot Length : ---
Building Width : ---	Lot width : ---



Width

Length must be the front of building or lot

**CODE RESEARCH**

Client's Name: XXXXXXXXXX

Zoning: B4

Business Name: XXXXXXXXXXXXXXXXXXXX

Address: 808 N Milwaukee Ave

City/State/Zip Code: Buffalo Grove, IL 60089

Note:

**GROUND SIGNS**

Are ground signs allowed? Yes:  Pole: \_\_\_\_\_  
No:  Monument: \_\_\_\_\_

Number of Signs allowed: \_\_\_\_\_ Distance to adjacent Ground Signs: \_\_\_\_\_

Maximum SF allowed per face: \_\_\_\_\_ Maximum sign height: \_\_\_\_\_

Minimum setback from lot: \_\_\_\_\_ Maximum overall height: \_\_\_\_\_

Minimum setback from building: \_\_\_\_\_ Visibility triangle: \_\_\_\_\_

Lighting restrictions: \_\_\_\_\_

Sign area formula: \_\_\_\_\_

NOTES: Face replacement only  
No restriction on letters and logos.

**WALL SIGN**

Are wall signs allowed? Yes:  No:

Number of Signs allowed: 1 Maximum Projection: not stated in the code but use up to 12"

Maximum SF allowed: 48.70 sq.ft.

Maximum Sign height: Not regulated Maximum logo height: 4.79 ft

Maximum sign width: 8.47 ft Maximum height of sign from ground: follow the Landlord regulation. Same height of other tenants

Maximum letter height: 4.79 ft Is area transferrable to another Yes:

Projection of sign to roof line: not regulated, but placing of sign must follow the Landlord regulation, see other tenants for example elevation: No:

Lighting restrictions: Buffalo Municipal Code, Title 15, Chapter 15.08 Electrical Code

Sign area formula: 20% of building wall area (wall where the sign is attached)

NOTES: 14.16.070 - Wall signs  
A Sign area refers to the area of the background of the sign with the exception of individual letters. The letters must fit into a rectangle with the length of the rectangle being not greater than one-third of the occupants store frontage, and the height of the rectangle being not greater than one-half of the portion of the building above the lintel.  
2.CATEGORY 2: Where a business has its own ground sign but no roof sign, 20% of the wall sign background area may be used for copy of enclosed sign.

**PERMIT REQUIREMENTS**

Permits can be applied via: Mail  Email  Online Portal   
 Permits can be applied by: Owner:  Contractor:  Authorized agent:   
 Signature required on application: <sup>see note</sup> Owner:  Contractor:  Authorized agent:   
 Business License required?: Yes:  No:   
 Sign Contractor registration required: Yes:  No:   
 Electrician registration required: Yes:  No:   
 Is inspection required: Yes:  No:   
 Timeframe of review: 2-3 weeks review process Size of documents: letter  
 Documents required: 1- Sign Permit application form 4-  
2- 3 sets of colored drawing with site plan 5-  
3- 1 set of drawing with Landlord signature 6-  
 Cost of permit: \$285 Other permit cost: \_\_\_\_\_  
 Is there a design review board th: Yes:   
 No:

NOTES: The applicant (either the owner, sign contractor, agent) can apply the Sign Permit application form.  
Payment can be mailed or pay in person.

**VARIANCE REQUIREMENTS**

Permits can be applied via: Mail  Email  Online Portal   
 Permits can be applied by: Owner:  Contractor:  Authorized agent:   
 Signature required on application: Owner:  Contractor:  Authorized agent:   
 Is there a zoning board meeting: Yes:  No:  No of meetings: \_\_\_\_\_  
 Person allowed to attend to attend the meeting: Owner:  Contractor:  Authorized agent:   
 Timeframe of review: \_\_\_\_\_ Size of documents: \_\_\_\_\_  
 Cost of application fee: \_\_\_\_\_ Is the fee refundable: \_\_\_\_\_  
 Documents required: 1- \_\_\_\_\_ 4- \_\_\_\_\_  
 2- \_\_\_\_\_ 5- \_\_\_\_\_  
 3- \_\_\_\_\_ 6- \_\_\_\_\_

NOTES: \_\_\_\_\_  
 \_\_\_\_\_  
 \_\_\_\_\_  
 \_\_\_\_\_  
 \_\_\_\_\_  
 \_\_\_\_\_

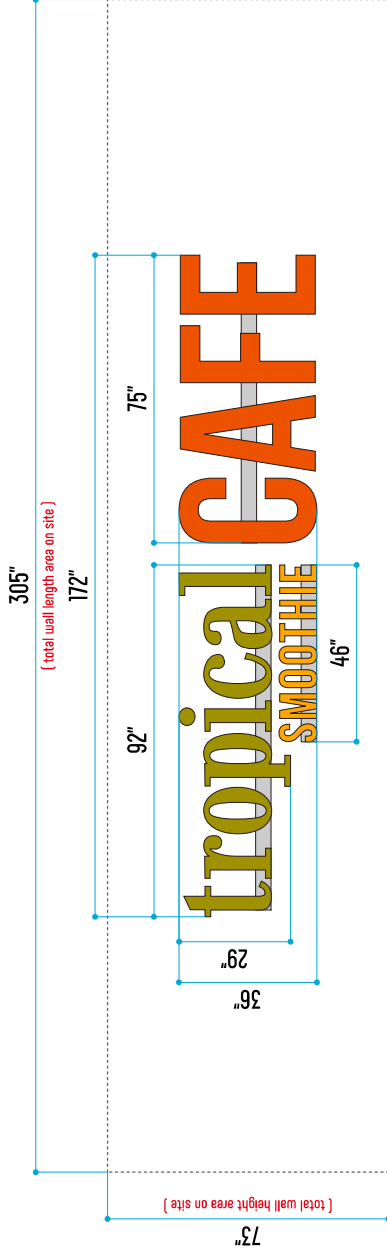

**FRONT VIEW**  
Scale @ 1:50

**A** Front-Lit, Plex-Face Channel Letters / Raceway Mounted  
Internally Illuminated Plastic Face Channel Letters

- QUANTITY : 1 set
- Overall Height : 36"
- Overall Length : 172"
- Total Sq. Ft. : 43 Sq. Ft.
- Returns : GLOSS BLACK
- Backs : GLOSS BLACK
- Trimecap : GLOSS BLACK
- Face : #7328 WHITE
- First surface translucent vinyl
- 3M Tropical Green 3630-31 20635
- 3M Sunflower 3630-25
- 3M Café Orange 3630-4987 20634
- Illuminations : White LED color
- Raceway : Paint to match Sugar Cookie 2160-70

Sugar Cookie 2160-70

**NOTE:**  
WHITE interiors for increased illumination  
All paint two-stage automotive acrylic finish

**ELECTRICAL NOTES**

Power to the sign must be done by a licensed electrical contractor or licensed electrician.  
Each sign must have:  
1. A minimum of one dedicated 120V 20A circuit  
2. Junction box installed within 6 feet of sign  
3. Three wires: Line, Ground, Neutral

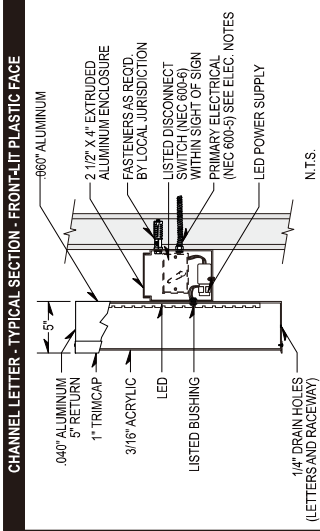

Existing shop front

Proposed Window Graphics

PLEASE REVIEW DRAWINGS FOR ACCURACY IN COLOR LAYOUT SPELLING APPROVAL STATES ALL CONTENT REPRESENTED IN THIS PROOF IS CORRECT



5500 N. Kedzie Ave Chicago, IL 60625  
773-267-6007 | sales@tfsigns.com

**Client Name:**  
Tropical Smoothie Café  
**Location:**  
808 N Milwaukee Ave. Buffalo Grove,  
IL 60089

**Start Date:** 02/21/2022  
**Last Revision:** 00/00/2022  
**Revision No.:** R-0  
**Page:** 1 of 2

- Client Approval
- Landlord Approval

**Sales Rep:**  
Seung Park  
**Designer:**  
Fidel Bago





**C** Tenant Monument Face Sign

Double Sided ( Internally Lighted )

QUANTITY	:	<b>2pcs.</b>
Overall Height	:	<b>20.8"</b>
Overall Length	:	<b>88"</b>
Total Sq. Ft.	:	<b>12.7 Sq. Ft.</b>
Face	:	<b>#7328 WHITE</b>
1st Surface	:	<b>Translucent Vinyl</b> <b>3M Orange 3630-4987 20634</b>
Retainer	:	<b>1 5/8" - Left &amp; Right</b> <b>0.5" - Top &amp; Bottom</b>



PLEASE REVIEW DRAWINGS FOR ACCURACY IN COLOR LAYOUT SPELLING APPROVAL STATES ALL CONTENT REPRESENTED IN THIS PROOF IS CORRECT



5500 N. Kedzie Ave Chicago, IL 60625  
773-267-6007 | sales@tfsigns.com

Client Name:  
Tropical Smoothie Café  
Location:  
808 N Milwaukee Ave. Buffalo Grove,  
IL 60089

Start Date: 02/21/2022  
Last Revision: 00/00/2022  
Revision No.: R-0  
Page: **2 of 2**

- Client Approval
- Landlord Approval

Sales Rep:  
Seung Park  
Designer:  
Fidel Bago



800-812  
NORTH MILWAUKEE AVE.

POTBELLY DRIVE THRU



tropical SMOOTHIE CAFE

verizon

ARTISAN  
VAPOR & CBD

BEST BEON CHICAGO

**800-812**  
**NORTH MILWAUKEE AVE.**

**POTBELLY** DRIVE  
THRU



tropical **CAFE**  
SMOOTHIE

**verizon** ✓

**ARTISAN**  
**VAPOR & CBD**

BEST NEON CHICAGO

tropical CAFE  
SMOOTHIE

808

SPACE  
AVAILABLE  
947.412.0808

SPACE  
AVAILABLE  
947.412.0808

RESERVED  
PARKING  
\$ 250 FINE





**Village of Buffalo Grove**  
**50 Raupp Blvd, Buffalo Grove, IL 60089**  
**Phone: (847) 459-2530 Fax: (847) 777-6046**  
**permits@vbg.org**

**Address: 808 MILWAUKEE AVE**

**Sign**

PIN: 15351030240000

Zoning: R6A

County:

**PERMIT #:** [REDACTED]

**ISSUED: 03/24/2022**

**EXPIRES: 09/20/2022**

**Work Description: Tenant Panel**

**Stipulations:**

**Value: 721.00**

APPLICANT / OCCUPANT:	OWNER:	CONTRACTOR:
<b>Applicant:</b> [REDACTED]	MJK Real Estate Holdings Co	[REDACTED]
<b>Occupant:</b> [REDACTED]	<b>Phone:</b>	<b>Phone:</b> [REDACTED]

**Subcontractor Type:**  
Electrical

**Subcontractor Name and Address:**  
[REDACTED]

**Subcontractor Phone:**

IL 60118

Fee Description	Quantity	Item Total
Sign - Tenant Panel-Reface	1.00	85.00
	Fee Total:	\$85.00
	Amount Paid:	\$85.00
Check Payment 5173	Balance Due:	\$0.00

**REQUIRED INSPECTIONS:**

The following list provides **GENERAL** information on Village inspections for your project. This list is intended to be used as a **GUIDE** for your reference during the construction process. Additional inspections and requirements not listed may be required. **A minimum 48-hour notice is required for all inspections.**

**Final Building**

By accepting this permit, I certify that the information in this permit is accurate and that all work will be done in compliance with all applicable laws including those regulating construction and zoning. I agree to schedule all required inspections and understand that the completed work will not be considered in compliance without approved final inspection(s). Failure to comply may result in citation and/or fines.

  
\_\_\_\_\_  
Director of Community Development



# Village of Buffalo Grove

## BUILDING PERMIT

**ADDRESS** 808 MILWAUKEE AVE  
**PERMIT TYPE:** Sign  
**ISSUED** 03/24/2022 **EXPIRES** 09/20/2022  
**OWNER** MJK Real Estate Holdings Co  
**CONTRACTOR** [REDACTED]

**Permit Number** [REDACTED]

To request an inspection, call (847) 459-2530 between the hours of 8:30 a.m. and 3:00 p.m. Monday through Friday. A minimum 48-hour advance notice is required to schedule an inspection. All inspection times are approximate.

Failure to have all phases of work inspected as required constitutes a code violation.

**- NOTE -**

Municipal Code, Section 9.38.037 Construction Regulations - Hours of Work

No work associated with (a) interior construction that produces distinctly and loudly audible sounds beyond the boundary of the property, (b) the preparation of land for development, or (c) exterior construction or exterior reconstruction of a structure, shall be allowed to occur on any weekday prior to 7:00 A.M. not after 7:00 P.M. No such activity shall be allowed to occur on either Saturday or Sunday prior to 8:00 A.M. nor after 7:00 P.M.

**NO MATERIALS OR DUMPSTERS TO BE STORED ON THE STREET OR PARKWAY.**

**This Notice Must Be Posted in Plain View From the Street and Remain Until  
Passing Final Inspection.**



**Village of Buffalo Grove**  
**50 Raupp Blvd, Buffalo Grove, IL 60089**  
**Phone: (847) 459-2530 Fax: (847) 777-6046**  
**permits@vbg.org**

**Address: 808 MILWAUKEE AVE**

**Sign**

PIN: 15351030240000

Zoning: R6A

County:

**PERMIT #:** [REDACTED]

**ISSUED: 03/24/2022**

**EXPIRES: 09/20/2022**

**Work Description:** Illuminated Wall Sign

**Stipulations:**

Value: 5,153.00

APPLICANT / OCCUPANT:	OWNER:	CONTRACTOR:
<b>Applicant:</b> [REDACTED]	MJK Real Estate Holdings Co	[REDACTED]
<b>Occupant:</b> [REDACTED]	<b>Phone:</b>	<b>Phone:</b> [REDACTED]

**Subcontractor Type:**  
Electrical

**Subcontractor Name and Address:**  
[REDACTED]

**Subcontractor Phone:**

IL 60118

Fee Description	Quantity	Item Total
Sign - Dir-Ground-Wall w Electric	1.00	200.00
	Fee Total:	\$200.00
	Amount Paid:	\$200.00
Check Payment 5172	Balance Due:	\$0.00

**REQUIRED INSPECTIONS:**

The following list provides GENERAL information on Village inspections for your project. This list is intended to be used as a GUIDE for your reference during the construction process. Additional inspections and requirements not listed may be required. A minimum 48-hour notice is required for all inspections.

**Final Building**

**Final Electrical**

By accepting this permit, I certify that the information in this permit is accurate and that all work will be done in compliance with all applicable laws including those regulating construction and zoning. I agree to schedule all required inspections and understand that the completed work will not be considered in compliance without approved final inspection(s). Failure to comply may result in citation and/or fines.

Director of Community Development



# Village of Buffalo Grove

# BUILDING PERMIT

**ADDRESS** 808 MILWAUKEE AVE  
**PERMIT TYPE:** Sign  
**ISSUED** 03/24/2022 **EXPIRES** 09/20/2022  
**OWNER** MJK Real Estate Holdings Co  
**CONTRACTOR** [REDACTED]

**Permit Number** [REDACTED]

To request an inspection, call (847) 459-2530 between the hours of 8:30 a.m. and 3:00 p.m. Monday through Friday. A minimum 48-hour advance notice is required to schedule an inspection. All inspection times are approximate.

Failure to have all phases of work inspected as required constitutes a code violation.

**- NOTE -**

Municipal Code, Section 9.38.037 Construction Regulations - Hours of Work

No work associated with (a) interior construction that produces distinctly and loudly audible sounds beyond the boundary of the property, (b) the preparation of land for development, or (c) exterior construction or exterior reconstruction of a structure, shall be allowed to occur on any weekday prior to 7:00 A.M. not after 7:00 P.M. No such activity shall be allowed to occur on either Saturday or Sunday prior to 8:00 A.M. nor after 7:00 P.M.

**NO MATERIALS OR DUMPSTERS TO BE STORED ON THE STREET OR PARKWAY.**

**This Notice Must Be Posted in Plain View From the Street and Remain Until Passing Final Inspection.**